



Culture Sector
Division for Heritage

United Nations
Educational, Scientific and
Cultural Organization

Organisation
des Nations Unies
pour l'éducation,
la science et la culture

Organización
de las Naciones Unidas
para la Educación,
la Ciencia y la Cultura

Организация
Объединенных Наций по
вопросам образования,
науки и культуры

منظمة الأمم المتحدة
للتربية والعلم والثقافة

联合国教育、
科学及文化组织

H. E. Mrs Eleonora Mitrofanova
Ambassador
Permanent Delegate of the Russian
Federation to UNESCO
UNESCO House

Ref.: CLT/HER/WHC/8424/RU/AS/MR 25 November 2015

Subject : **Transmission of the report of the ICOMOS advisory mission to the
World Heritage property "Kizhi Pogost"**

Dear Ambassador,

Please find enclosed the report of the ICOMOS advisory mission to the World Heritage property "Kizhi Pogost", invited by the Russian authorities from 28 September to 1 October 2015.

Your authorities may wish to provide factual comments on the mission report at their earliest convenience.

May I take this opportunity to thank you for your cooperation and support in the implementation of the *World Heritage Convention*.

Please accept, dear Ambassador, the assurances of my highest consideration.

Mechtild Rössler
Director
World Heritage Centre

cc: National Commission of the Russian Federation for UNESCO
National Focal Point for World Heritage
ICOMOS International

ICOMOS

Report on the ICOMOS Advisory Mission to Kizhi Pogost (C 544)

28th September – 1st October 2015



TABLE OF CONTENTS

1.	ACKNOWLEDGEMENTS	3
2.	MAIN THREATS IDENTIFIED PREVIOUSLY	3
3.	MISSION PARTICIPANTS	4
4.	MISSION TERMS OF REFERENCE	5
5.	MISSION REPORT AND RECOMMENDATIONS	5
	5.1. Review of the over-all state of conservation of the property	5
	5.2 Review of the restoration works in the Church of the Transfiguration	7
	5.3. The engineered safety systems	13
	5.4. The Supervisory Committee for the restoration works	15
	5.5. Educational center for conservation of wooden monuments	16
	5.6 Experts Web-site	16
	5.7 Plan and Area Development	16
	5.8 Monitoring Mission	18
	ANNEX A – List of Participants	
	ANNEX B – Terms of Reference for this mission	
	ANNEX C – Statement by the Supervisory Committee	
	ANNEX D – Terms of reference for the Engineering system project	
	ANNEX E – Suggested reinforcement of quadrangle	
	ANNEX F – Mission Programme	
	ANNEX G – Photographs	

1. ACKNOWLEDGEMENTS

ICOMOS is grateful to the authorities of the Russian Federation for the invitation and assistance they provided for the advisory mission to the World Heritage property of Kizhi Pogost. The mission would like to convey its gratitude to the Russian National Commission for UNESCO, for its assistance and support.

The mission would like to convey its gratitude to Pavel Mosolov, Deputy Director of the Department of state protection of cultural heritage sites, and to Irina Kazey, Officer of the unit for state protection of cultural heritage sites, Department of state protection of cultural heritage sites; both from the Russian Federation Ministry of Culture, for their active participation in meetings, presentations and site visits.

The mission also thanks the staff and specialists of the Kizhi State Museum-Reserve for the exceptional hospitality, availability, strong communication and valuable information on the current situation of the World Heritage property, during numerous working meetings and site visits. Special thanks to Mr. Dimitriy D. Lugovoy, Director of the Kizhi State Museum-Reserve, who actively supported and participated in this mission.

2. MAIN THREATS IDENTIFIED PREVIOUSLY

The World Heritage Committee has examined the state of conservation of the property on twelve occasions since the inscription of the property in 1990. The threats that previously have been underscored include:

- a. Threats to structural integrity and deteriorated state of the Church of the Transfiguration.
- b. Absence of an integrated management plan and an operational management system that addresses overall management of the property, tourism management, land use management, management of infrastructure development on Kizhi Island (visitor facilities, artefacts, warehouse, etc.), and establishment of the buffer zone.
- c. Absence of a completed "Statement of Outstanding Universal Value" for the site.
- d. Absence of conservation guidelines and principles to guide consistent decision making regarding reinforcement, treatment of witness marks, and retention or replication of historic fabric and details.
- e. Threats to the Outstanding Universal Value of the church, such as any delay in the restoration process due to lack of funding, as well as change of personnel in the restoration team, which will lead to loss of invaluable experience and understanding of this particular building, and of the complicated restoration work.

3. MISSION PARTICIPANTS

Participants in the mission and related meetings and site visits were as follow:

ICOMOS Advisory Mission representative:

- Arnt Magne Haugen, ICOMOS, Norway

Participants from the Russian Federation Ministry of Culture:

- Pavel Mosolov - Deputy Director of the Department of state protection of cultural heritage sites, Russian Federation, Ministry of Culture
- Irina Kazey - Officer of the unit for state protection of cultural heritage sites, Department of control, supervision and licensing in the field of cultural heritage, Russian Federation, Ministry of Culture.

Participating members of the Russian Federation Ministry of Culture Committee on supervision of the restoration process:

- Tatyana Vakhrameyeva – Director of CJSC LAD, first category architect-restorer
- Mark Kolyada - First category architect-restorer, head of architectural and restoration workshop, Research Institute SPETSPROEKTRESTAVRATSIYA, Saint-Petersburg, member of the Architect Union
- Vyatcheslav Orphinsky – Member of Russian Academy of architecture and building science, Doctor of Architecture
- Victor Popov – Architect of the VITOSLAVITSY museum of wooden architecture (V.Novgorod), First category architect-restorer
- Victor Drenin – Architect-restorer of wooden architecture

Representatives of the contractors:

- Vladimir Rakchmanov – Chief architect of the restoration project of the Church of the Transfiguration
- Vitaliy Skopin, Director of LLC ARTS ZAONEZHIE
- Alexey Chusov - Deputy Director of LLC ARTS ZAONEZHIE
- Aleksander Savelyev - Director of LLC SKF ALEKON
- Iosif Rasha – Chief engineer of the restoration project of the Church of the Transfiguration

Guest architect-restorer of wooden architecture

- Boris Lurie – First category architect-restorer

Participants from Museum Administration, supervision & craftsmen:

- Dmitriy D. Lugovoy - Acting Director
- Olga Titova – Deputy Director of development and international relations
- Nadezhda Ludanik – Deputy Director of financial and economy control
- Aleksander Lyubimtsev - Head of Conservation
- Tatyana V. Nezvitskaya – Head of unit for conservation
- Andrey Kovalchuk – Head of the Carpenter Centre
- Tatyana Brygina, Interpreter WHS Unit

4. MISSION TERMS OF REFERENCE

The terms of reference for the advisory mission were defined based on the recommendations from the July 2014 advisory mission to the property, as well as the *Operational Guidelines for Implementation of the World Heritage Convention*.

The mission carried out by ICOMOS from September 28th – October 1st 2015 was an advisory mission, with the main goal of advising the State Party and the Kizhi Museum. However, its recommendations are intended to be consistent with the previous decisions made by the World Heritage Committee and with recommendations made by the World Heritage Centre and ICOMOS during the reactive monitoring missions, and previous advisory missions, consequently this report should be read in conjunction with this documentation, in particular the July 2014 advisory mission report.

The main focus of this advisory mission was the technical aspects of the restoration project on the Church of the Transfiguration, particularly the reassembly of the log work of the 4th and 5th tiers, the challenge of deformations of the reassembled tiers, and the repair work of the 3rd tier. In relation to the latter, the focus was especially on needs and possibilities related to proposed reinforcements of the quadrangle structure carrying the weight of the upper part of the church.

Questions regarding other issues than the restoration work such as status of the management plan, the buffer zone and area development were not discussed during this mission and will only be briefly mentioned in the report.

5. MISSION REPORT AND RECOMMENDATIONS

5.1. Review of the over-all state of conservation of the property

Evaluation of factors of conservation issues that can potentially affect the Outstanding Universal Value of the property, including its conditions of authenticity and integrity:

Though the restoration project is in a very challenging period, the progress is good, and the work is being carried out with a high quality in every way, as stated above. Still, the mission has identified some factors regarding the building and the process of restoring it, which might affect the Outstanding Universal Value of the property.

- a. **Strengthening systems:** The use of modern methods and materials to an excessive degree might affect the integrity of the church. Yet, it is the impression of the mission that the restoration project puts more and more trust in the original construction, and when possible reinforcements are discussed, it is more focused on adapting it to the original construction now than before. The mission considers it important to still keep focus on these issues as the project moves on, and as new questions of reinforcement appear.

Recommendation: The mission reiterates previously given recommendations, that the introduction of new strengthening systems should be made to a minimum

degree, and that traditional methods should be preferred. Modern materials and technology should be avoided.

- b. **Delay in the restoration process:** Previous missions have repeatedly stressed the importance of the restoration project continuing with no interruption. It has also been stated that a delay in the restoration project could be a danger to the Outstanding Universal Value of the property. The 2014 mission noted that a delay in the restoration work was a reality at the time of the mission, but the project has later managed to perform a considerable amount of work, using the museums Carpenter Centre and short-term contracts with the contractors Zaonezhie and Alekon. The mission has been informed that the contracts for 2015 are now fulfilled, and the Carpenter Centre will keep up the work, securing the building for the winter.

This mission reiterates the views of previous ICOMOS mission, that halting conservation work is a danger to the Outstanding Universal Value of the church.

- c. **Funding of the restoration process:** Generally, the economic situation of the Russian Federation has been more difficult the last year than before. In this situation, it is important to focus on the considerable effort that has been put into the restoration over the last years. The completion of the project is now within reach, and it will be beneficial to keep the project running with upheld quality, until it is finished.

Recommendation: The mission urges the Russian authorities to ensure that funding for the next stage of restoration is made available.

- d. **Contracting methods:** As on previous missions, the contractors for the restoration project (*Zaonezhie* and *Alekon*) participated fully in the various meetings and briefings. The Advisory Mission was again positively impressed by the knowledge and commitment of the contractors. All the contractors have been involved in the restoration process from the beginning, and have earned valuable experience and understanding of this complex building. It would not be possible to obtain the same specialized knowledge any other way. It is crucial for the success of the restoration that key persons from every part of the restoration team continue within the project to ensure that the experience gained so far is not lost.

The mission reiterates the concern of earlier missions, that contracting procedures for future phases of the work might lead to awarding future contracts to firms with less capacity, skills and ability to properly estimate and carry out the scope and cost of the work. Even a new highly skilled team have no possibility to match the experience that the current contractors have gained through the work at this particular building. A change of personnel will most probably lead to less effective work, and a need to go through every discussion on methods and procedures once again, which would set the project considerably back.

Recommendations: The mission recommends that the State Party investigate all possible means to ensure bidding contractors have appropriate skills and quality workmanship. It is also recommended that measures be undertaken to

ensure that key skilled persons from all the recent contractors are kept within the project team. Furthermore, it is essential that the capacity of the museum carpentry staff be protected and maintained.

- e. **Potential loss of interior due to conservational challenges:** There has been some discussion on the conditions of the beams of the “heaven” ceiling from the church interior. The Russian paintings conservators, working with these interior parts, are very clear in their view that the beams should be kept in a museum, and that an exact copy should be made for the Church of the Transfiguration.

The mission recognizes the great challenges of putting the beams for the heaven ceiling back into its original positions in the church, including loss of decoration paint over time. Nevertheless, removing the original ceiling beams, which is both part of this almost complete church interior as well as part of the original construction, would cause loss of authenticity and integrity. This would affect the Outstanding Universal Value of the church in a negative way.

5.2. Review of the restoration works in the Church of the Transfiguration

5.2.1. Status of the restoration project

At the time of the July 2014 advisory mission, the 6th and half of the 5th tier had been repaired and reassembled in the building. The 4th tier had also been removed from the church, and was in the carpenters centre, fully restored and temporarily assembled inside the restoration hall.

At the present time, the restored 4th and 5th tiers are fully reassembled in the church. The 4th tier is assembled without the domes and the cover of the roofs of the “bochkas” – the “barrel roofs”. The 3rd tier has been removed from the church, and it is now reassembled in the workshop, ready for restoration. The third tier includes the quadrangle construction, which has been subject to discussions on reinforcement. The 1st and 2nd tiers are still in their original position, untouched. The development of the restoration project for the 1st and the 2nd tiers is being carried out at the moment, and the detailed design of the restoration project for the 3rd tier is about to be completed.

The mission was again positively impressed by the progress made on the restoration process and the high level of care and workmanship. In July 2014, the main challenge was deformation of the church walls, and different proposals for strengthening of the walls were proposed. Now, the project team has regained full control of the building and its movements, and today there is hardly any deviation to be measured at all.

It is apparent that the project team has a greatly developed understanding of traditional carpentry, and the application of conservation principles. The team is constantly evolving these skills as the restoration continues, and the experience they have gathered from this work is a great benefit to the project. It is the perception of the mission that the positive development largely can be ascribed to the valuable experience and knowledge built up during the restoration process.

The 2014 advisory mission as well as earlier missions gave recommendations on various aspects of the restoration. As far as this mission could see, the restoration

works are generally of a high quality and in accordance with earlier missions recommendations and agreed restoration principles. Challenges related to adjustments made during earlier restoration works, as well as wall deformations during the present reassembling works have been dealt with in a skilful and carefully considered way.

The July 2014 mission was informed that the contracts for the three companies working on the restoration project had expired. Since then, all the contractors got short-term contracts to conduct the work that was done this summer, in cooperation with the carpenter centre of the museum. At the time being, the contracts for 2015 are fulfilled, and a new tender procedure is to be carried out. This once again involves major uncertainty according to the companies that have followed the restoration process from the beginning, and whether it will be possible to keep the key personnel within the project. Still, there has been some positive development regarding this issue: The mission was informed that Mr. Vladimir Rakhmanov, Chief architect of the project, now has a contract that lasts until the project is completed.

It is the view of the 2015 advisory mission that a potential change of contractors at this point is one of the most serious concerns for a successful completion of the project.

5.2.2. Structural reinforcement of the building

One challenge that has been discussed previously on several occasions is the need for structural reinforcement of the building. Within the structure of the Church of the Transfiguration, several points have previously been identified as areas of structural weakness. Over the past 18 years, ICOMOS has regularly provided recommendations which have been to:

- ✓ restore the historic structure first,
- ✓ aim to allow it to support itself,
- ✓ add minimal reinforcement interventions if necessary,
- ✓ resist introducing state-of-the-art modern materials and technology.

The need for structural reinforcement and potential methods of reinforcement was one of the main subjects of this advisory mission. The mission team has noted that the discussion on this topic has developed positively in the direction of earlier ICOMOS mission advice. As the restoration project goes on, the project team is getting the weak points under control, one by one. It seems very clear to the mission that the project team now puts more trust in the original structure, and the discussions have developed positively because of this.

The project team has decided on a very important strategy on reinforcement in line with earlier ICOMOS recommendations:

- ✓ To restore the historic construction first.
- ✓ To try to use traditional and reversible methods to repair weaknesses.
- ✓ Reinforcements are only to be considered if it is proven that it is absolutely necessary, and if traditional methods are proven to be inadequate.

The following parts of the construction were discussed:

a. Foundation:

The foundation has been a major point of weakness, and probably the major cause of the older deformations of the church. A new underground foundation was made in 2011, and the foundation is now stable. Thus, this point of weakness has been eliminated.

b. The walls of the first octagon and binding posts: One of the previously identified weak points is the tall walls of the lower octagon, between the annexes. At the time of the July 2014 advisory mission, the walls had deformations, and the building continued moving towards its old deformations. Following the recommendations of the mission, so-called *binding posts* were mounted on the diagonal walls. (Binding posts are wooden posts, one on the outside of the wall and one on the inside, each pair bound together with bolts through the wall.) The deformations are corrected, and at the present time, the building has virtually no deformations at all.

There has been discussion on the amount of bolts needed in each pair of binding posts for sufficient strength. While calculations indicate that there should be bolts through every second layer of wall logs, which makes a total of approximately ten bolts per pair of binding posts, the team mounting the binding posts has been of the opinion that four bolts per pair of binding post are sufficient. At the time being, the rest of the bolts have not been installed, and it does not seem to be a problem.

It is important that binding posts are fixed with as few bolts as possible, to keep the construction flexible. The more bolts, the bigger chance of cracks or other problems connected with the posts. More bolts also leads to more holes in the original material. In an upright wall, it will take extreme forces to break the bolts of a binding post, and this is not likely to happen, even with very few bolts. It is the view of the mission that the number of bolts already installed in the binding posts should be sufficient.

Recommendation:

The mission recommends that the binding posts are retained as today, and that no more bolts are added, unless serious movements occur. The state of the binding posts and the bolts should be regularly checked to assure that they function as intended.

c. The supporting ring of the “heaven” ceiling (“Nebo”): The “heaven” ceiling over the central part of the octagon has the shape of a low, octagonal tent, or a truncated pyramid. This construction, which functions as an important support for the church walls, also exerts a certain pressure on the walls, pushing outwards. The support ring, whose function is to resist this pressure, has been adjusted several times during history, and today the joints that should lock the ring and hold everything together, has lost their function. Thus, the supporting ring does no longer counteract against the pressure from the ceiling, and the loads will push right against the walls. Several strategies have been described to reinforce the supporting ring to make it fit to take the pressure from the

ceiling. The suggestions include reinforcement of the joints, strengthening metal hardware, fixation of the ring to the walls, metal tightening devices beside the beams crossing the annexes, and the addition of supportive wooden structures. Some descriptions received prior to the mission also include the use of self-tapping screws. The possibility of relieving the walls from pressure by hanging the ceiling from the constructions above, as it has partly been before, has also been mentioned.

The strengthening of wooden constructions can be very challenging. The timber construction of the Church of the Transfiguration is a very flexible construction, and it can withstand heavy loads because of this. Fixing single parts of the construction using strengthening metal hardware might cause certain parts of the construction to be more rigid. More rigidity might make these parts subject to increased forces, which in turn might lead to damage. Any introduced elements should therefore be designed to maintain full flexibility of the construction. Regarding screws, this is relatively new technology for the strengthening of log buildings. There is no experience on how this will work in a long term, and the use of screws should be avoided in this building.

The mission states that there are two strategies of reinforcement of the supporting ring that stands out as more acceptable than the others:

- ✓ To support the “heaven” ceiling by attaching it to the constructions above. The possibilities to relieve the walls from pressure this way should be considered thoroughly.
- ✓ If there is still need for any extra measures to keep the walls from spreading, the installation of steel tension rods close to the beams of the support ring should be sufficient to stop the walls from sliding apart. This is a flexible form of reinforcement, which will affect the function of the construction very little. Nevertheless, steel tension rods should only be installed if absolutely necessary, and in that case, as inconspicuous as possible.

It is also important to consider whether it is certain that the opening of joints has been caused by horizontal pressure from the ceiling “heaven”, or if it also could have been caused by the spreading of the octagon.

Recommendation:

The mission reiterates the recommendations of earlier missions, to reduce added reinforcement interventions to an absolute minimum, and to resist introducing state-of-the-art modern materials and technology. The possibilities to support the ceiling by attaching it to constructions above should be investigated, in order to reduce the need of reinforcement as much as possible.

- d. Strengthening of the quadrangle beams in the upper part of the octagon: What is referred to as the quadrangle beams is a construction of traversed logs, spanning across the octagon. Altogether, the first quadrangle consists of five pairs of traversed logs, forming a square construction to rest on for the

second octagon, i.e. the upper part of the church. In the space between the logs there were two vertical rows of wooden blocks, to distribute weight. These blocks were removed when the supportive metal frame were installed in 1982. The quadrangle beams has been pointed out as one of the weak points of the construction before, and potential methods for reinforcement were thoroughly discussed during this mission. All participants in the meetings agreed that reinforcement should only be introduced if it was proven to be needed.

Mr. Iosif Rasha, chief engineer of the project expressed the need for a physical load test of the construction before a reinforcement system is introduced. He has also made a suggestion for reinforcement, based on filling the open gaps of the quadrangle construction with new logs, and bracing the walls of the quadrangle with an x-shaped cross of wood laminate (ANNEX E). Several of the mission participants pointed out that the existing quadrangle had no visible damage, and that the existing construction already had proven its abilities. Some participants also expressed concern that a test might be based on an excessively estimated load.

Making accurate calculations on log constructions is extremely difficult, since every log is different from the next one. Even the best of engineers will have to add a certain safety margin to such an estimate. Tests have proven that round logs are 3 - 4 times stronger than a square cross-section from the same log, and that it has higher bending strength than glued laminated timber. In calculations, the strength of round logs tends to be underestimated. Round logs that have been permanently loaded for a long time, might have permanent deformations, like deflections, without this affecting the strength of the log.

To carry out a physical test is a good idea, and it would undoubtedly give knowledge of interest both for this project and for other restoration projects. However, it is very important that the test be carried out on a model and not on the original construction from the Church of the Transfiguration, as this would imply a risk of damage. Like the rest of the building the quadrangle beam construction is very flexible, and reinforcements should not hinder this flexibility. Reduction of flexibility in the construction could alter the load forces, leading to overload in other parts of the construction. The flexibility of the construction must be considered an important factor for its durability, and it should not be disturbed.

The safest information available on the construction of the Church of the Transfiguration is the empirical facts from the building. As pointed out by several Russian experts, the quadrangle beam construction has carried the upper part of the church for more than 260 years before the supportive steel framework were installed. There is no visible damage on the beams, and this indicates that there should really be no danger in putting this construction back into the church without any further reinforcement. However if there are strong indications that the logs have weakened, or wind forces will be bigger than before, a simple compromise is to install only one more layer of logs on the top or the bottom of the quadrangle. If this is carried out, it should be made with as little intervention with the original construction as possible.

Recommendation:

The mission recommends to trust the old construction, and to re-establish it in its original state in the building. If there are very strong indications that reinforcements are needed, this must be conducted in the simplest possible way, and reduced to a minimum.

5.2.3. Decorated beams of the interior “heaven”- ceiling (“Nebo”):

The beams of the “heaven” ceiling from the church interior have been and are still being treated by paintings conservators to preserve the decorations. The mission was informed that the conservation process is only intended for storage under controlled conditions. If the decorated beams are to be put back into its original position in the church, a much more profound conservation process is needed. The conservators expressed their professional point of view, including that putting the beams back in the church will increase the danger of damage and decomposition, and will make future conservation work more challenging. Russian paintings conservators are very clear in their view that the beams should be kept in a museum, and that an exact copy should be made for the Church of the Transfiguration.

The mission recognizes the great challenges of putting the beams for the heaven ceiling back into its original positions in the church, and the danger for loss of decoration paint over time. Nevertheless, in the Church of the Transfiguration most of the interior is preserved, including the iconostasis and its icons, which is quite unique in this part of Russia. Furthermore, it is a fact that the decorated ceiling beams are also an important part of the original construction, contributing to stability of the walls of the church. Removing the original ceiling beams, as part of an almost complete church interior and original construction, would cause a loss of authenticity and integrity, and thereby affect the Outstanding Universal Value of the church in a negative way.

The mission was also informed that the iconostasis will be put back into the church. The conservation of the icons and the frame was not brought up as a challenge, but it is the view of the mission that the concern should be even bigger for the iconostasis. Some parts of the iconostasis have been sent to Moscow for conservation, due to reasons such as temperature requirements for the conservation, and to keep up the work during winter season. Being conserved in a different climate than in the church, might increase the vulnerability of the decorated surfaces when the icons are put back into the church.

Recommendation: The mission recommends that the goal of the restoration work should be to re-establish every part of the church, including the construction and the interior, in a state as close to the original as possible. All conservation work should be done according to this.

5.2.4. Surface treatment of roof elements:

It has been suggested to treat the new roof cover material with preservatives and water repellent to ensure longer life of the elements. In earlier missions, the possibilities of using for example pine tar to conserve building parts was discussed, but this has not been supported by ICOMOS. During the whole project an important principle for the restoration has been only to use traditional methods and materials. This is essential to keep the authenticity and integrity of the building, and earlier

missions advised against the introduction of new chemicals and materials that have not been commonly used in the Russian wooden buildings tradition. Furthermore, modern preservatives and fungicides contain volatile substances, and most of them will only be effective for a very short time. Put on an outer surface, preservatives might still affect the colour and the aging of the wood, and it might destroy the “silver” image of the roofs. Getting the building parts to last long should be based on high quality of the materials, skilled artisans and good maintenance.

Recommendation:

Treatment with modern chemicals for the purpose of prolonging the life of wooden parts should be avoided, and only traditional methods and materials should be used. The long life of the church should be based on carefully chosen materials and high quality carpentry, followed by regular inspections and maintenance.

5.2.5. Monitoring of movements of the construction:

The 2014 advisory mission made a recommendation on monitoring of the building, to keep control of movements. The project team has established measuring points on chosen places in the building during the proceeding of the restoration process, and the measuring points are regularly monitored to follow any changes in the construction. The current mission was informed that the latest months there had been hardly any movement registered at all. This is a good indication that the implemented strategies to prevent shrinkage and sinking of new logs work as intended.

5.3. The engineered safety systems

The museum made presentations on the development of the engineering system project. The presentation was clear, and the mission got a good impression of the development of the engineering system project. There has been a considerable work done on the planning of these systems.

5.3.1. Fire protection:

The museum has worked further with the plans for installing a suppression system in the churches and the Bell tower, in accordance with the recommendations of the 2011 and the 2013 missions. A room for technical equipment will be needed for the suppression system, and the museum suggests locating this in a special designed compartment in the basement of the Church of the Transfiguration. After the presentations, the plans were discussed and commented by the project team and the members of the Supervisory Committee. There were positive reactions, but several experts also expressed their concern on whether this huge investment would be beneficial in relation to the cost.

Experiences from Norwegian stave churches during the last 20 years indicates that there is quite a risk of uncontrolled release. It has also shown the obvious fact that every fire extinguishing system needs frequent service and maintenance to work properly. In the same way, routines have to be controlled and updated regularly. In average there has been one uncontrolled release every year in the 28 Norwegian stave churches, and according to this, statistically every church might have an uncontrolled release every thirty years.

The mission is positively impressed with the plans presented by the museum. It is very positive that the museum keeps the focus on fire safety, since the risk of fire will always be one of the most serious threats to a wooden building of this size. It is important that the Risk Management Plan is regularly updated, to reflect on the actual conditions at any time, and that special focus is given on prevention of fire, and on backups, if something does not work as planned. It is also important to keep in mind that preventing a fire from starting is the best method of fire-fighting. All possible ways for a fire to start, and how to prevent that should be investigated. The risk management plan should also include how to handle an uncontrolled release. Since frost is an important factor in the Church of the Transfiguration, and since it is possible to have the building continuously watched, an important consideration is if a manual or an automatic release of a suppression system is the most expedient.

It is also an important fact that a complicated, automatized system always has a bigger risk of failure, and a greater demand on maintenance than a simple system. It is therefore very important to make sure the simple and less costly measures are working before putting a great effort into developing the more complicated systems. Different systems should overlap and function independently, regardless of each other. A fire detection system will generally detect a fire before the suppression system is released, and manual efforts will always be crucial, regardless of any automatic systems. For the safe operation of the fire protection system, and to avoid its uncontrolled release, it is crucial that the system is managed by qualified and trained personnel, and that the equipment is maintained regularly.

Regarding the technical compartment, it is the view of the mission that it could be placed in the basement of the church, without being a threat to the Outstanding Universal Value of the property. This is because there is much space there, it is possible to build a compartment without intervening with the church construction, and this area of the building will not be visible or accessible for the public. Nevertheless, locating the technical equipment inside the church also has some clear disadvantages to it. First, there is a need to control the equipment regularly, and it will need maintenance at certain times, regardless of activities in and around the church. It also has to be easy access to the room to transport equipment in and out when needed. Finally, located in the church, the compartment might not be accessible in an emergency, which might be very inconvenient. Based on this, all possibilities of locating the technical compartment outside the church should be investigated before a conclusion is made.

Recommendation: The mission reiterates the previous recommendations of the 2011 and 2013 reactive monitoring missions, and the 2011 and 2014 advisory missions, that the State Party implement the fire protection and security plans as presented because these will improve the level of protection and the quality of the environment near the World Heritage property.

Recommendation: The less costly parts of the complete fire protection system, like routines for guarding and simple preventive measures, must be kept updated and operative, regardless of the planning and implementation of more advanced systems. Lightning protection systems should be controlled regularly, for damage and errors, especially the parts near the ground that are particularly exposed to damage.

5.3.2 Electrical heating, lights and ventilation:

In a future room for technical equipment there might be a need for electrical heating and ventilation. It is very important that this does not affect the climate inside the church. The Church of the Transfiguration is built as a summer church and has never had heating installed. It is crucial that this situation is maintained in the future, as any climate change in the church will affect the valuable church interior. Electrical lights might also affect the painted surfaces of the interior.

A significant percentage of all fires in buildings are caused by errors in the electrical system, and every electrical cable installed in the church building will increase the risk of a fire in the future. Thus, the installation of electrical cables in the church should be kept to an absolute minimum.

5.3.3 Architectural lighting:

The possibilities on architectural lighting of the churches were discussed on general basis, but no specified plans for this were presented.

The general view of the mission is that lighting of the churches should be done carefully, and only to a small degree. Along with development of modern electrical technology, it has become quite trendy to make artistic illumination of architecture. In some contexts, this might create interesting and pleasant effects, but often the illumination itself becomes the point, and the architectural values secondary. Illumination done to highlight special features of a building, or in attempt to create special effects, will usually be a mistake on historical buildings. The impression of a historical building can easily be distorted and alienated by unsuccessful architectural lighting. A more modest, general lighting is considered the best strategy to emphasize the architectural and historical values of Kizhi Pogost, and will probably also be most practical for guarding and safety of the property.

Recommendation: The mission advises against artistic illumination of the Church ensemble, in an attempt to create visual effects, and recommends that only modest, general lighting is planned. Elements or cables for the purpose of illuminating the church ensemble or the pogost, should not be attached to the buildings.

5.4 **The supervisory committee for the restoration works**

The supervisory committee is working very well. Five members of the committee were present during the meetings, and in addition, Boris Lurie, architect-restorer of wooden architecture, was invited to the mission as a guest. They all provided valuable input and considerations during our discussions. The mission welcomes the work done by the supervisory committee, and notes with satisfaction that the group continue to play an important role with its high level of competence and experience. Together with the contractors and the museum staff this makes a very competent group and the mission find the discussions very useful.

5.5 **Educational Centre for conservation of wooden monuments**

The educational and training Centre on conservation of wooden architecture is now a fact. The Centre offer a study program with six units of practical and theoretical courses, spanning from architecture theory, from wood as a material to practical carpentry and restoration training. The Centre's ambition is to be a leading

competence centre for wood conservation in Russia, and they also wish to arrange international courses on wood-conservation, with lecturers and participants from several countries. The mission is positively impressed by this development. This is considered a very good way of keeping up the level and development of the competence at the museum, and sharing the experience and competence that has been built up will be very useful to other professionals and other projects both within Russia and outside the Russian borders.

5.6 Experts Web-site

The posting of progress photos on this site for periodic review by ICOMOS has proven to be a very useful tool and should continue. The mission recommends that regular uploading of project photos to the web site set up for the purpose should continue as a very effective monitoring tool for the World Heritage Centre and the Advisory Bodies.

Recommendations: The mission recommends that regular uploading of project photos to the web site as previously set up for this purpose should continue as a very effective monitoring tool for the World Heritage Centre and the Advisory Bodies.

5.7 Management Plan and Area Development

5.7.1 Management plan:

The management plan was not a subject of this mission, and it was not discussed. The mission was informed that the management plan is in its final phase, and will be sent to the federal authorities for approval this year.

5.7.2 Area development:

It has been a constant issue on almost every mission that changes are made on the island without being supported by a completed management plan. This mission also noticed some changes, and some of these changes both seem unnecessary and inconsiderate in relation to the museum monuments. The negative development observed since last year include a big floating pier outside the Gogolevsky guesthouse, and building of a piece of road from Yakovlev's house towards the Gogolevsky. The only purpose of the piece of road seems to be to make it possible to drive a little closer to the Gogolevsky house. The Gogolevsky guesthouse already has a pier for transport of goods and persons, and the purpose of the new floating pier is unknown.

There has also been some positive development of the Island, as a response to the recommendations of earlier missions. The floating restaurant, which was in a very exposed location, has now been moved further north along the shore of Kizhi Island, and has now less visible influence on the pogost site. In addition to this, the smoking area by the entrance zone has been moved, and it is now located by the shore of the lake, away from the wooden floor and the kiosk area. There is little vegetation there, and this is a much better solution according to the risk of fire.

5.8 Monitoring Mission

Next year will be a critical period for the Kizhi Pogost World Heritage property with the completion of the 3rd tier, progress of the work of the 1st and 2nd tier, the

reassembly and stabilization of the supporting ring for the “heaven” ceiling, and further discussions on reinforcement of the upper part of the building.

Recommendations: The advisory mission recommends that the State Party might wish to consider a follow-up monitoring mission in 2016 in order to assess the progress of the conservation project and the management plan.

ANNEX A

List of participants of the ICOMOS mission on Kizhi Island

Mission period: September, 28 – October, 1 2015

№	Name	Title
ICOMOS experts		
1.	Arnt Magne Haugen	Senior adviser to the Cultural Heritage Directorate of Norway, Adviser to the National Fortification Heritage.
Members of the RF Ministry of Culture Committee on supervision of the restoration process		
2.	Tatiana Vakhrameeva	Director of CJSC LAD, first category architect-restorer
3.	Mark Kolyada	First category architect-restorer, head of architectural and restoration workshop of Research Institute SPETSPROEKTRESTAVRATSIYA, Saint-Petersburg, member of the Architect Union
4.	Vyacheslav Orfinsky	Member of the Russian Academy of Architecture
5.	Viktor Popov	Architect of the VITOSLAVITSY museum of wooden architecture (V.Novgorod), first category architect-restorer
6.	Viktor Drenin	Architect-restorer of wooden architecture
Representatives of the RF Ministry of Culture		
7.	Pavel Mosolov	Deputy Director of the Department of state protection of cultural heritage sites, RF MC
8.	Irina Kazey	Officer of the unit for state protection of cultural heritage sites, Department of state protection of cultural heritage sites, RF MC
Representatives of contractors		
9.	Vladimir Rakhmanov	Chief architect of the restoration project of the Church of the Transfiguration
10.	Vitaly Skopin	Director of LLC ARTS ZAONEZHIE
11.	Alexey Chusov	Deputy Director of LLC ARTS ZAONEZHIE
12.	Alexander Savelyev	Director of LLC SKF ALEKON
13.	Iosif Rasha	Chief engineer of the restoration project of the Church of the Transfiguration
Guest architect-restorer of wooden architecture		
14.	Boris Lurie	First category architect-restorer

List of the Kizhi Museum employees participating in the Mission

№	Name	Title
1.	Dmitry Lugovoy	Acting Director
2.	Olga Titova	Deputy Director of development and international relations
3.	Nadezhda Ludanik	Deputy Director of financial and economy control
4.	Alexander Lubimtsev	Head of Conservation
5.	Tatiana Nezvitskaya	Head of Unit for preservation and historical - architectural complex and landscape integrity
6.	Andrey Kovalchuk	Head of the Carpenter Centre
7.	Tatiana Brygina	Interpreter, WHS Unit

ANNEX B

to the Consulting Agreement
№ ____ dd. _____

Приложение 1
к Договору об оказании
консультационных услуг
№ ____ от _____

TERMS OF REFERENCE FOR
THE ICOMOS ADVISORY MISSION TO THE WORLD HERITAGE PROPERTY
KIZHI POGOST, RUSSIAN FEDERATION

**Техническое задание
для консультативной миссии ИКОМОС
на Объект Всемирного Наследия «Кижский Погост»,
Российская Федерация**

г. Петрозаводск
2015
Petrozavodsk
2015

« ____ » сентября,

« ____ » September,

<p>The World Heritage property of Kizhi Pogost was inscribed on the World Heritage List in 1990 under cultural criteria (i), (iv) and (v).</p> <p>In 2015, the State Party of the Russian Federation invited an ICOMOS advisory mission to the property with the main objective of assessing the results of the restoration work on the Church of the Transfiguration.</p> <p>Taking into consideration the recommendations of the previous ICOMOS advisory mission carried out in 2014, as well as the Operational Guidelines for the Implementation of the World Heritage Convention, the 2015 advisory mission should review and assess the following key issues:</p>	<p>Объект Всемирного Наследия «Кижский Погост» был внесен в список Всемирного Наследия в 1990 году в соответствии с культурными критериями (i), (iv) и (v).</p> <p>В 2015 году государство-участник Российская Федерация пригласило консультативную миссию ИКОМОС на ОВН с основной целью произвести оценку результата реставрационных работ, проводимых на Преображенской церкви.</p> <p>Принимая во внимание рекомендации предыдущей консультативной миссии ИКОМОС, которая состоялась в 2014 году, а также Руководства по выполнению Конвенции об охране Всемирного наследия, консультативной миссии 2015 следует рассмотреть и оценить следующие ключевые вопросы:</p>
<p>a) The overall state of conservation of the site</p>	<p>a) Общее состояние сохранности объекта</p>
<p>b) The results of the restoration works performed on the Church of the Transfiguration, in particular:</p> <ul style="list-style-type: none">- the reinforcement/strengthening system of the church	<p>b) Результаты реставрационных работ, выполненных на Преображенской церкви, в частности:</p> <ul style="list-style-type: none">- система усиления/укрепления церкви- результаты реставрационных работ по

<p>- the results of the restoration work on the 4th tier and the reassembly of the monument tiers, including the inspection of the dismantled logs of the 3rd tier</p>	<p>4 технологическому поясу, сборке поясов памятников, в том числе осмотр демонтированных бревен 3 яруса</p>
<p>c) The implementation of the 2014 ICOMOS advisory mission recommendations on the restoration works</p>	<p>с) Выполнение рекомендаций консультативной миссии ИКОМОС 2014 по реставрационным работам</p>
<p>d) The engineered safety system of the site, notably the approval of the technical specifications for the site's engineering networks</p>	<p>d) Система обеспечения безопасности ОВН, в частности, утверждение технических характеристик по инженерным сетям ОВН</p>
<p>e) Consulting support of damage identification and restoration processes</p>	<p>e) Консультативное сопровождение процессов дефектовки и реставрации</p>
<p>f) The engineering system of reinforcement/strengthening of the church (general provisions of the restoration project)</p>	<p>f) Инженерная система усиления/укрепления церкви (общие положения проекта реставрации)</p>
<p>Based on the results of the above-mentioned assessments and the on-site discussions with the State Party representatives, the advisory mission shall prepare a report on the findings and recommendations to the State Party. ICOMOS shall submit the report to the World Heritage Centre within four weeks of the mission and to the Kizhi Open Air Museum within 60 days from the end of the mission</p>	<p>На основании результатов оценки вышеуказанных вопросов и обсуждений на месте с представителями государства-участника, консультативная миссия должна подготовить отчет с рекомендациями и замечаниями для государства-участника. ИКОМОС должен предоставить отчет в Центр Всемирного наследия в течение четырех недель после окончания миссии, Музею-заповеднику «Кижы» - в течение 60 дней с момента окончания миссии.</p>
<p>The International Council on Monuments and Sites (ICOMOS)</p> <p>Director General _____ Marie-Laure Lavenir stamp</p>	<p>The Kizhi State Open Air Museum of History, Architecture and Ethnography</p> <p>Первый заместитель директора _____ Д.Д.Луговой м.п.</p>

ANNEX C

ПРОТОКОЛ

Совещания комиссии Министерства культуры Российской Федерации по наблюдению за процессом проведения реставрационных работ на объекте культурного наследия Преображенской церкви на о. Кизи

28-30 сентября 2015 года

о. Кизи

Члены комиссии:

1. Вахрамеева Т.И.
2. Дренин В.П.
3. Попов В.А.
4. Орфинский В.П.
5. Коляда М.И.
6. Лурье Б.Д.
7. Мосолов П.О.
8. Казей И.В.

Участники совещания:

- От музея-заповедника «Кизи»:
Луговой Д.Д.-и.о. директора,
Ковальчук А.Л.- начальник ПЦ,
Незвицкая Т.В.- руководитель службы,
Любимцев А.Ю.- руководитель службы.
- От генпроектировщика ООО ПИ «Геореконструкции»:
В.С. Рахманов, автор проекта, гл. архитектор,
И.К. Раша, гл. инженер систем современного усиления конструкций и вывешивания церкви.
- От подрядных организаций:
Скопин В.А.- директор ООО АРЦ «Заонежье»,
Чусов А.А.- зам. директора ООО АРЦ «Заонежье»,
Савельев А.А.- директор ООО СКФ «Алекон».

I. По результатам ознакомления с процессом реставрации церкви Преображения Господня на о. Кизи, выполненным с момента предыдущего посещения объекта члены комиссии пришли к следующему выводу:

1. Выполненные работы по реставрации 5 и 4 пояса показали у исполнителей (ООО АРЦ «Заонежье», отдела «Плотницкий центр музея») качество и профессионализм, что подтверждается их квалификационной аттестацией. В целом выполненные работы одобряются.
2. Объем работ запланированный на этот год выполнен. Собран на погосте 4-й технологический пояс, завершено покрытие бочек алтаря с полицами, установлена главка алтаря. Работы по реставрации 3-го пояса не выполнены в связи с необходимостью выполнения корректировки проекта современного усиления конструкций на завершающий этап реставрации церкви.
3. Продолжается разработка проекта на завершающую стадию реставрационных работ на церкви, которая будет выполнена к 01.12.2015 г.
4. Члены комиссии согласовали техническое задание по инженерным сетям на церкви.

II. Члены комиссии настоятельно рекомендуют:

1. Продолжить реставрацию сложившимся коллективами реставраторов, хорошо зарекомендовавших себя с начала проведения работ на объекте и детально изучивших его уникальные конструкции, впервые примененную на церкви Преображения Господня систему исправления деформаций, освоивших реставрацию деструктурированных элементов, систему вывешивания на уникальном и сложном объекте: ООО ПКФ «Алекон», ООО АРЦ «Заонежье», «Плотницкий центр» музея.
2. Просить Министерство культуры Российской Федерации выдать разрешения музеео-заповеднику «Кижский», отделу «Плотницкий центр» по окрытию бочек прирубов 4-го технологического пояса и на реставрацию элементов технологического пояса для безостановочного проведения работ.
3. Принимая во внимание решения предыдущих миссий, просить Министерство культуры Российской Федерации обеспечить в полном объеме финансирование реставрационных работ, в том числе постоянный ежегодный авторский надзор проектировщиков в лице В.С. Рахманова с разработкой рабочих чертежей, инженерно-технического сопровождения по монтажу/ демонтажу металлокаркаса, системы вывешивания в лице И.К. Раши. Стоимость авторского надзора необходимо рассчитать по фактическим затратам, в связи с уникальностью проведения производства работ.

III. В ходе работы комиссии были обсуждены возникшие вопросы и приняты решения:

A. Усиление четвериковых балок в основном восьмерике.

1. Проектировщики предлагают собрать на площадке отреставрированный 3-й технологический пояс согласно проектным предложениям (историческим) и провести испытания надежности элементов четвериковых балок. В приложение № 1 отражено мнение каждого участника комиссии по данному вопросу.
2. Рабочая группа предлагает подготовить авторскому коллективу проектировщиков:
 - Обоснование необходимости проведения испытаний надежности элементов четвериковых балок.
 - Определить критерии испытаний, при этом не допустить разрушающих моментов в историческом материале.
 - Методику испытаний.
3. При выполнении п.2 представить пакет документов для рассмотрения на научно-методический совет (секция деревянного зодчества) при Министерстве культуры России или при возможности на объекте после реставрации 3-го пояса.

B. Конструкция неба

1. Российские эксперты рекомендуют отказаться от установки подлинных конструкций в силу неудовлетворительного состояния тябел. Изготовить новые конструкции неба по историческим образцам. При этом окончательно решение принимается архитектором по результатам балочных конструкций неба по месту.

2. Рекомендуется установить обвязочное кольцо по контуру сруба по тлям неба в соответствии с решениями автора проекта.

С. Обработка антисептиком и гидрофобным составом нового кровельного материала церкви (теса, лемеха, водостоков) необходима для более длительного сохранения элементов.

Вела протокол Т.В. Незвицкая Незвицкая Т.В.

Члены комиссии:

Вахрамеева Т.И. Т.И. Вахрамеева Дренин В.П. В.П. Дренин Попов В.А. В.А. Попов
Орфинский В.П. В.П. Орфинский Коляда М.И. М.И. Коляда Турье Б.Д. Б.Д. Турье
Мосолов П.Ю. П.Ю. Мосолов Казей И.В. И.В. Казей

Участники совещания:

Луговой Д.Д. Д.Д. Луговой Ковальчук А.Л. А.Л. Ковальчук Незвицкая Т.В. Т.В. Незвицкая
Любимцев А.Ю. А.Ю. Любимцев В.С. Рахманов В.С. Рахманов И.К. Раша И.К. Раша
Скопин В.А. В.А. Скопин Чусов А.А. А.А. Чусов Савельев А.А. А.А. Савельев

Приложение № 1 «Особое мнение по вопросу А.Усиление четвериковых балок в основном восьмерике.»

MINUTES
of the Meeting of the commission of the Ministry of Culture of the Russian Federation
on supervision of the restoration process of the world heritage site the Transfiguration
Church on the Kizhi Island

28-30 September 2015

Kizhi Island

Members of the Commission:

1. Vakhrameeva Tatiana
2. Drenin Viktor
3. Popov Viktor
4. Orfinsky Vyacheslav
5. Kolyada Mark
6. Lurie Boris
7. Mosolov Pavel
8. Kazey Irina

Participants of the Meeting:

The Kizhi Museum:

Lugovoy Dmitry - Acting Director,
Kovalchuk Andrey - Head of the Carpenter Centre,
Nezvitskaya Tatiana - Head of Unit for preservation and historical - architectural complex and
landscape integrity,
Lubimtsev Alexander - Head of Conservation.

General designer "Georekonstruktsiya" Ltd:

Rakhmanov Vladimir - author of the project, chief architect,
Rasha Iosif - chief engineer of the modern reinforcement system and lifting of the Church.

Subcontractors:

Skopin Vitaly - Director of LLC ARTS ZAONEZHIE,
Chusov Alexey - Deputy Director of LLC ARTS ZAONEZHIE,
Savelyev Alexander - Director of LLC SKF ALEKON.

I. After the inspection of the restoration process of the Transfiguration Church on the Kizhi Island implemented as of the moment of the previous visit to the site the members of the Commission made the following conclusions:

1. The implemented works on restoration of the 5th and the 4th tiers revealed high-level professionalism and quality of works of the responsible organizations (LLC ARTS ZAONEZHIE, the Carpenter Centre of the Kizhi Museum). It is also confirmed by their certificates. In general the implemented works are approved.
2. The works planned for this year has been fully implemented. The 4th tier has been assembled on the Pogost, the cover of the altar bochkas with decorative roofs has been completed, and the altar dome has been installed. The restoration works of the 3rd tier have not been completed due to the necessity to correct the project of modern reinforcement of constructions for the final stage of the Church restoration.

3. The elaboration of the project of the Church restoration final stage is still being carried out and will have been completed by 01.12.2015.

II. Members of the Commission strongly recommend the following:

1. To continue the restoration by the well-established team of restorers who has gained good reputation from the start of works on-site, who has thoroughly studied the unique constructions of the Church and the deformation correction system applied for the first time to the Transfiguration Church, who has successfully acquired the knowledge of restoration of the damaged elements and work with the lifting system of the unique and complicated site: LLC SKF ALEKON, LLC ARTS ZAONEZHIE, the Carpenter Centre of the Kizhi Museum.
2. To ask the Ministry of Culture of the Russian Federation to issue an official permission to the Kizhi Museum and the Carpenter Centre to dismantle the bochkas of the annexes of the 4th tier and to restore the elements of the tier to ensure nonstop restoration process.
3. Taking into account the decisions of the previous missions, to ask the Ministry of Culture of the Russian Federation to provide full financing of the restoration works including elaboration of the detailed drawings and the continuous annual field supervision by the designers represented by Vladimir Rakhmanov, and engineering and technical support on installation/ dismantlement of the metal frame and the lifting system by Iosif Rasha. In relation to the unique character of the implemented works the cost of the field supervision is to be calculated on the basis of actual costs incurred.

III. The Commission discussed the issues arose and the following decisions were accepted:

A. Reinforcement of quadrangle beams in the main octagon.

1. The designers propose to assemble the restored 3rd tier on-site in accordance with the project (historic) proposals and to carry out the reliability test of the elements of the quadrangle beams. The Annex 1 includes the opinion of each participant of the Commission on this issue.
2. The work group proposes the project designers to prepare the following:
 - Justification of the necessity to carry out the reliability test of the elements of the quadrangle beams.
 - Criteria for the test envisaging prevention of damage of historic material.
 - Testing methods.
3. In the course of the article 2 implementation the package of documents shall be submitted for consideration by the Scientific and Methodological Council (wooden architecture section) under the Ministry of Culture of the Russian Federation or, if possible, on the site after the restoration of the 3rd tier.

B. Construction of the “heaven” ceiling

1. Russian experts recommend refusing of installation of the original constructions due to unsatisfactory condition of the transoms. The new elements of the “heaven” ceiling shall be made. The final decision shall be made by the architect after the inspection of the “heaven” ceiling beams on the site.

2. It is recommended to install the capping beam along the walls of the octagon and the transoms of the “heaven” ceiling in accordance with the decisions of the project author.

C. It is also necessary to treat the new roof cover materials (thin planks, shingles, drainage) with preservative and water-repellent to ensure long service life of the elements.

Minutes recorded by _____ Nezvitskaya T.

Members of the Commission:

Vakhrameeva T. _____ Drenin V. _____ Popov V. _____
Orfinsky V. _____ Kolyada M. _____ Lurie B. _____
Mosolov P. _____ Kazey I. _____

Participants of the Meeting:

Lugovoy D. _____ Kovalchuk A. _____ Nezvitskaya T. _____
Lubimtsev A. _____ Rakhmanov V. _____ Rasha I. _____
Skopin V. _____ Chusov A. _____ Savelyev A. _____.

Annex 1. «Individual opinions on the issue A. Reinforcement of quadrangle beams in the main octagon».

Annex 1 – Individual opinions on the issue

«Reinforcement of quadrangle beams in the main octagon»

Rasha I.

In case the results of the test of the restored historic quadrangle are negative, the reinforcement construction shall be made in accordance with the norms and the repeated test shall be carried out.

Kolyada M.

Testing is needed to try its methods in practice on similar constructions to make our decisions as unbiased as possible.

Savelyev A.-

Popov V., Lurie B., Drenin V.

It is unreasonable to make the test in the workshop as it might damage the historic construction.

It is proposed to restore the historic structure of the quadrangle beams on the Pogost with putting gradual load on them which will appear as a result of assembly of the upper tiers. Constant monitoring of the beams condition will allow making decisions on the need to reinforce the structure, for example, by the installation of clamps on the beams to ensure its vertical alignment.

Vakhrameeva T.

It is necessary to restore the original quadrangle beams with their historic vertical connections and to monitor the monument's condition when the other tiers are assembled; and to reinforce the construction, if necessary. The upper element shall be restored right away.

Orfinsky V.

The historic constructions shall be maximally preserved, and the reinforcement shall be reversible.

Skopin V.

Iosif Rasha couldn't respond to all of the questions and the presented arguments are not enough to justify the tests. The reinforcement is likely to be installed in accordance with the project author. I perceive the idea with respect, but it needs to be updated and developed.

Lubimtsev A.

The test of the construction with gaps between the logs in the workshop will not consider the facts that the bochkas of the 2nd tier rest on the walls of the first octagon and are some kind of counterforce protecting the construction from the wind load what significantly reduces the load on the whole building. Moreover the Museum has the opportunity to monitor the condition of the construction with gaps between the logs. This is why the 3rd tier shall be assembled on the site; and the monitoring of the deformations of the loaded constructions shall be organized to make the decision on the necessity of reinforcement.

Chusov A.

The historic constructions are unique and “operated” for more than 300 years without any defects in wood, they are still in good condition, this is why they shall be installed back and monitored. There is no need for testing because it is unclear how to simulate all loads during the testing.

The historic constructions do operate and there is a need for monitoring only. Modern reinforcement shall be accepted after its installation in the monument upon the receipt of the results of the monitoring.

Participants of the Meeting

Name	Telephone	E-mail
1. Vakhrameeva T.		
2. Drenin V.		
3. Popov V.		
4. Orfinsky V.		
5. Kolyada M.		
6. Lurie B.		
7. Mosolov P.		
8. Kazey I.		

ANNEX D

Project

Terms of reference for the development of engineering systems project of the Church of the Transfiguration

Note. The preservation of the OUV, authenticity and integrity of the monument, constructive integrity and the subject of protection is required from all the project solutions of the terms of reference. All decisions must be agreed with the Customer.

1. GENERAL DATA

№ p/p	LIST OF BASIC REQUIREMENTS	CONTENTS OF REQUIRMENTS
1.1.		
1.2.		
1.3.	Information about the construction area	The Church of the Transfiguration included into the UNESCO World Heritage Site “Kizhi Pogost”, the cultural heritage site of federal significance.
1.4.		
1.5.		
1.6.	Terms of construction	Beginning of construction 2018 End of construction 2020
1.7.		
1.8.		
1.9.	Project stages	Permission of the Ministry of Culture of the RF for the project works implementation; Engineering survey; Pre-project stage – development of three versions of the general concept of engineering solutions; Project documentation (PD); Estimate documentation (ED); Working documentation (WD); – Development of special technical conditions for firefighting systems in accordance with the order of the Ministry of Regional Development of the RF №36 of 01.04.2008 “On the procedure of the special technical conditions development and agreement for the project documentation elaboration for capital construction project”. – Approval of the special technical conditions (STC) in the Ministry of Construction and Housing and Communal Services

		of the RF and in the Russian Emergency Situations Ministry.
1.10.		
1.11.		.

2. BASIC REQUIRMENTS TO THE PROJECT SOLUTIONS

№ p/ p	LIST OF BASIC REQUIREMENTS	CONTENTS OF REQUIRMENTS
2.1	General requirements	<p>1. In the process of the estimate documentation development it is necessary to ensure the compliance of the proposed solutions with the requirements of preservation of scientific, artistic, historic and cultural value of the site. There should be provided conditions for its current use and physical safety, preservation of the authenticity and the present appearance of the monument without changing its features forming the subject of protection.</p> <p>2. In the documentation development the scientific supervision by the restoration project author should be implemented.</p>
2.2		
2.3		
	The number of levels	The church is divided into three levels: basement, church premises and unused space above the “heaven” ceiling.
2.4	<p>Constructive solutions, members and materials of carrying and enclosure structures</p> <p>Technical solutions on the underground space development considering the influence on the surrounding buildings</p>	<p>The project documentation should include construction of compartments for technological equipment placement (power electrical equipment, equipment of low current systems, firefighting equipment) in the basement.</p> <p>The carrying and enclosure structures should be introduced to the monument without violating the integrity of its structures and elements.</p> <p>All the technological equipment and technological compartments should be arranged in such a way to provide an access to all structures of the church for the current maintenance, state monitoring and restoration.</p> <p>Prohibition of the underground space development on the Pogost territory except for the basement of the Transfiguration Church. In case of necessity it should be agreed with the museum services.</p>
2.5	Technological solutions and equipment	In case of imported equipment appliance the necessity of appliance should be justified

2.6	<p>Engineering systems of the building</p> <ul style="list-style-type: none"> - heating; - ventilation; - Requirements to the automatic control system of fire protection - Dispatch systems of engineering networks - Water supply - Sewage and drainage 	<p>Electrical heating of the technological compartments should be provided. Automated control of the electrical heating should be provided.</p> <p>In case of the use of forced ventilation of the technological compartments the energy efficient ventilation system should be designed.</p> <p>The forced ventilation of the monument premises is not required. The technological compartments and equipment should be placed and arranged in such a way not to hinder natural ventilation of the monument.</p> <p>The automatic control system of fire protection should ensure in the automated mode the implementation of measures on fire elimination in response to the signal of the automatic fire alarm system.</p> <p>Automatic control and dispatching system should provide control the set parameters of engineering networks</p> <p>The project should include water supply for external and internal fire extinguishing and internal firefighting water pipe line.</p> <p><u>External firefighting.</u></p> <p>Adjust the existing pumping station project</p> <p>The external firefighting water line should be circular. In winter period there should be a possibility of water drainage from the external firefighting system. The project should include the possibility to replace water pipe lines, stop valves and measurement instruments. The firefighting water pipe lines should be made of stainless steel.</p> <p>The external fire water line should be equipped with fire robots on the basis of remote controlled fixed monitors (hereinafter complex). Every monitor should be controlled both remotely and manually.</p> <p>The complex should detect and extinguish fires with the simultaneous notification of the Central Dispatching Point about the work and the state of the complex. It should also work together with the television surveillance system and fire alarm. The automated, remote and manual control of the complex should be provided.</p> <p><u>Internal firefighting.</u> The aerosol firefighting with water mist should be considered as a variant for internal firefighting in the premises of the Church of the Transfiguration. The water pipe lines should be hidden. The geometry of the construction should be taken into account.</p> <p>The project should include water drainage from the site in the</p>
-----	---	---

	<ul style="list-style-type: none"> - Electrical lighting; - Electrical equipment; - the system of automatic fire alarm and the system of warning and people evacuation in case of fire Security alarm system Lightning protection system Circuit television system 	<p>moment of firefighting implementation and after it.</p> <p>The interiors, basement, technological compartments and the space above the “heaven” ceiling should be lighted</p> <p>Distribution device should be placed in the technological compartment</p> <p>The system of automatic fire alarm and the system of warning and people evacuation should be constructed on the basis of addressable detectors with further sending signals to the Central Dispatching Point</p> <p>All detectors, audible and visual alarms installed on the site should be painted in the color of adjacent structure.</p> <p>Cable lines should be maximally hidden or, in case if it is impossible, painted in the color of adjacent structure</p> <p>Security alarm system should be built on the basis of addressable detectors with the subsequent transmission of signals to the Central Dispatching Point.</p> <p>In accordance with the norms Lightning strike counter should be installed</p> <p>Circuit television system (CTS) should be built with the use of networks cameras day/night both outside and inside of the site with the picture transmission to the Central Dispatching Point on Kizhi Island.</p>
2.7	<p>External engineering networks</p> <p>A method for laying of engineering services</p>	<p>Power supply should be provided by means of two mutually redundant cable lines.</p> <p>The engineering systems should be compatible with the projected external firefighting system</p> <p>There should be provided the possibility of technical maintenance of the networks. The networks should not hinder the possibility to maintain the structures of the monument and they should not have a negative impact on the subject of the protection of the monument.</p>
2.8	<p>Development of a monitoring project</p> <p>2.8.1 Deformation monitoring</p> <p>2.8.2. Monitoring of biodeteriorations</p>	<p>Development of the deformation monitoring project and parameters of temperature and humidity regime of the structures and premises of the church should be made within the project elaboration</p> <p>All equipment (including the producer) should be agreed with the Customer</p> <p>Deformation monitoring is carried out through operational control of stress and strain behavior of carrying elements and structures of the monument in the process of use.</p> <p>Monitoring should be implemented through geodetic observations and measurements</p> <p>Microclimate parameters should be measured in an automatic mode and gathered in the unified data base. Monitoring sensors for temperature and humidity parameters should be placed in all premises of the church including the exhibition space, the basement</p>

		and above the “heaven” ceiling. The sensors should be included in the National Register of Measuring Equipments. They should undergo the initial and periodic State verification. There should be provided the possibility to change the location of the sensors specified in Table 1 that are placed in the internal unused spaces
2.9		
2.1		
2.1	Recultivation of the territory	After the reconstruction recultivation of the territory should be made including restoration of the soil broken in the construction process. Improvement of the territory should be performed in accordance with the historical background upon agreement with the Customer
2.1		
2.1	Architectural lighting	Architectural lighting should contribute to creation of variant composition of the lighted site emphasizing and highlighting its architectural features and composition of the ensemble.
2.1		

3. ADDITIONAL REQUIREMENTS

No p/p	LIST OF REQUIRMENTS	CONTENTS OF REQUIREMENTS
3	Development of separate project solutions in several versions or on a competitive basis	Draft project solutions on engineering networks appearance and architectural lighting should be developed in three versions
	Implementation of scientific, research and experimental works in the process of projecting and construction	Construction structures and facilities should be examined in the process of projecting
3	Preparation of demonstration materials	Versions of project solutions for the appearance of engineering networks and architectural lighting should be presented in the form of albums.

ANNEX E

Suggested reinforcement of quadrangle

Усиление стенки четверика.

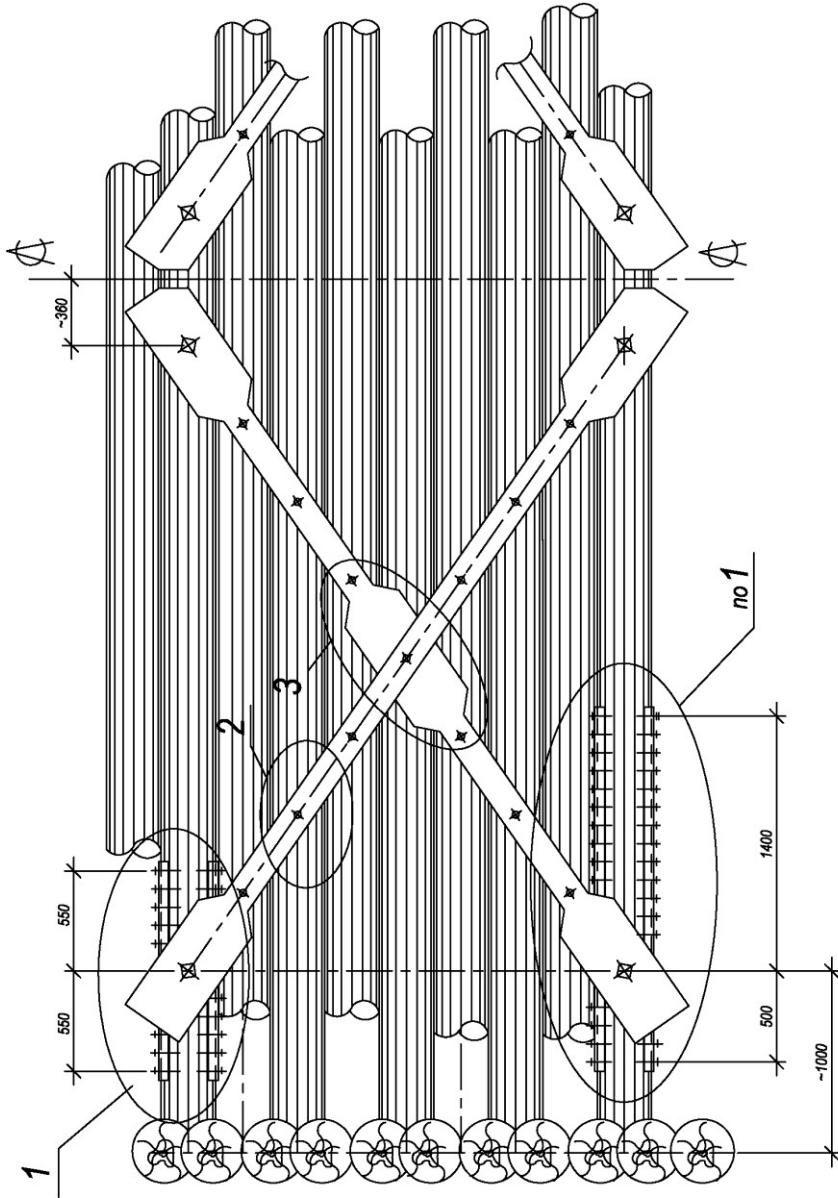

Имя	Кол. уч.	Лист	№ док.	Подпись	Дата
Гл. инж. пр.	Реша	И.К.			
Н. контр.					
Проверил					
Исполнил	Соловьев	С.М.			

Музей-заповедник Киж

Усиление

Усиление стенки четверика.

стадия	лист	листооб
П		

ООО "Стройреконструкция"

Имя, Подг.	Подпись и дата	Взам. инв.№
Должность	Фамилия	Подпись
Дата		

ANNEX F

**Programme
for the ICOMOS advisory mission
on the issues of the Church of the Transfiguration restoration
September 2015
Petrozavodsk, Kizhi**

Day 1 (28 September)	
Russian participants meeting	
07.00	Arrival to Petrozavodsk
11.30	Departure to Kizhi Island
13.30	Lunch
14.00 – 15.30	Transfer of the Russian participants to the WHS “Kizhi Pogost”, fieldwork
16.00 – 17.00	Work in the restoration center
17.00 – 17.30	Drafting of decisions by the Russian participants
18.00	Dinner
Day 2 (29 September)	
Assessment of the overall conservation state of the Site	
08.00-8.40	Breakfast
8.40-13.00	Work in the restoration center (Russian participants)
13.30	Arrival of the ICOMOS mission expert to Kizhi Island
14.00-15.00	Lunch
15.00-16.00	Welcoming the mission participants. Background information, the Mission program. Report on implementation of the 2014 mission’s recommendations.
16.00-18.00	Transfer of the participants to the WHS “Kizhi Pogost” <u>Fieldwork:</u> - Assessment of the overall conservation state of the Site. - Acquaintance with the restoration works performed on the Church of the Transfiguration (T.Nezvitskaya, A.Kovaltchuk) - Acquaintance with the results of the restoration work on the 4 th restoration tier (T.Nezvitskaya, V.Skopin) Questions and discussion
18.00 – 21.00	Transfer of the participants to the Restoration Center Coffee break <u>In the Restoration Center:</u> - Inspection of the dismantled logs of the 3 rd tier of the Church of the Transfiguration. - Engineering reinforcement/strengthening system of the church (general provisions of the restoration project) Questions and discussion
21.00	Dinner

Day 3 (30 September)	
Mission's work on issues of continuation of the restoration	
08.00-8.40	Breakfast
08.40 – 11.00	<p>Transfer of the participants to the museum depository (Pudozh sector)</p> <p>Inspection of the structural elements of the iconostasis (radial transoms - tyablas, “heaven”, friso, circular transom) of the Church of the Transfiguration</p> <p>Transfer of the participants to the Restoration center</p> <p><u>Reports:</u></p> <ul style="list-style-type: none"> - Engineering safety system of the Site: approval of the technical specifications for the engineering networks of the Site (A.Lubimtsev) <p>Questions and discussion.</p>
11.00 – 13.30	<p>Transfer to the Kizhi pogost</p> <p>Fieldwork: engineering reinforcement/strengthening system of the church</p>
13.30 – 14.30	Lunch
14.30 – 18.00	<p>Transfer to the Restoration center</p> <p>Questions and discussion. Summarizing the results of the mission's work and decision making:</p> <ul style="list-style-type: none"> - Assessment of the restoration work by the mission - Engineering reinforcement/strengthening system of the church (general provisions of the project) - Approval of the technical specifications for the engineering networks of the Site - Other decisions
18.30	Gala dinner
Day 4 (1 October)	
Additional meetings and consultations	
08.00-08.40	Breakfast
08.40 – 13.30	<p>Transfer to the Restoration center</p> <ul style="list-style-type: none"> - Additional meetings and consultations with experts on restoration and monitoring of the conservation state of the Site (if necessary) - Additional visit of the Site (if necessary) <p>Questions and discussion. Provision of additional information at the request of the mission expert.</p>
13.30-14.30	Lunch
15.45	Departure

ANNEX G
Photographs



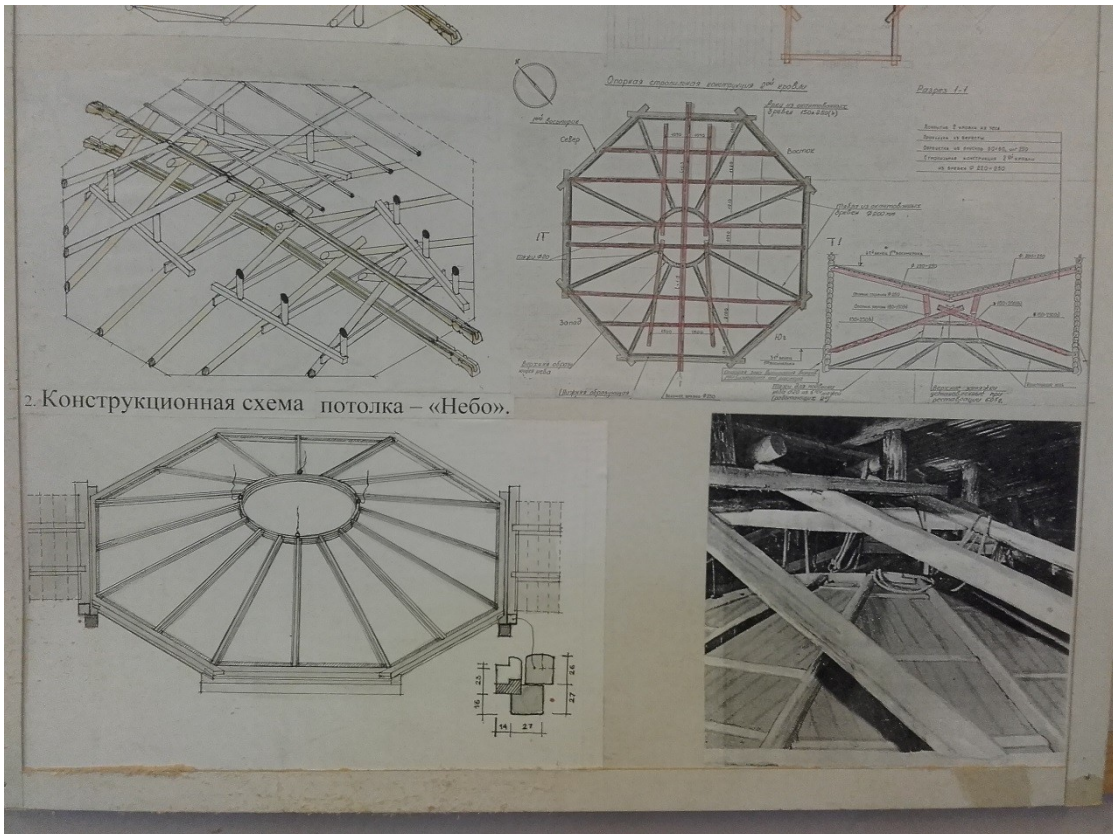

The «heaven» ceiling – «Nebo».



The supporting ring of the «heaven» ceiling. The joints of the beams spanning across the top of the annexes are broken, and have lost their function. The screw in the lower log is a point for monitoring.



The decorated beams of the interior «heaven» ceiling.



The quadrangle beam structure.



The big floating restaurant has been moved and is no longer visible from the pogost.



The smoking area by the entrance zone has been moved since last year, and is now in a much safer place, by the lake in a spot with little vegetation or flammable material.



The new pier on the eastern shore by the guest house.



A piece of new road makes it possible to get closer to the guest house with a car.



View from the lake Onega.